

## GMC-MSH Sealed Magnetic Catch

### Features

- Body material is compliant with the Food Sanitation Act (standard test for rubber implement (except baby bottles), containers and packaging)
- Blue body for easy visual inspection for food industry
- Body covered with silicon rubber reduces noise during door closure
- Small body with strong magnetic force (neodymium magnet)
- Washer fitted in the body fixing hole prevents silicone rubber from tearing when screwed

### Notes

- Do not use in strong acid and strong alkaline environment
- Do not use in contact with steam, hot water and water
- Max. temperature: 80°C
- Do not scrape strongly, as damaged magnetic surface may tear. Recommended to use flat counter plates.
- Recommended counter plates sold separately: **GAS-68**, or **GMC-JM49**

### Recommended Screws

- Truss screw M4

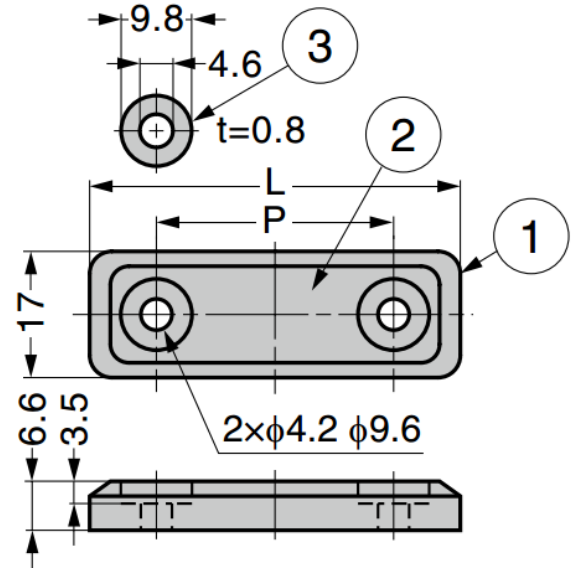

No.	Part Name	Material	Finish / Colour
①	Body	Silicone Rubber (Q)	Blue
②	Magnet	Neodymium	Nickel
③	Washer	Stainless Steel (SUS304)	Plain

### Body

Part No.	L	P	Magnetic Force	
<b>GMC-MSH45BU</b>	45	27	19.6 N	2 kg
<b>GMC-MSH50BU</b>	50	32	39.2 N	4 kg

### Counter Plates (Sold Separately)

Part No.
<b>GAS-68</b>
<b>GMC-JM49</b>